

LED-248
LED-248R

User Manual

Please read the instructions carefully before use

TABLE OF CONTENTS

1. Safety Instructions
2. Technical Specifications
3. How to Set the Fixture
4. How to Control the Fixture
5. DMX 512 Configuration
6. DMX 512 Connections
7. Troubleshooting
8. Fixture Cleaning

1. Safety Introductions



WARNING

Please read the instructions carefully which includes important information about the installation, operation and maintenance.

- Please keep this User Manual for future consultation. If you sell the fixture to another user, be sure that they also receive this instruction booklet.
- Unpack and check carefully there is no transportation damage before using the fixture.
- It's important to ground the yellow/green conductor to earth in order to avoid electric shock.
- Disconnect main power before servicing and maintenance.
- Maximum ambient temperature is $T_a : 40^{\circ}\text{C}$. Don't operate it where the temperature is higher than this.
- In the event of serious operating problem, stop using the fixture immediately. Never try to repair the fixture by yourself. Repairs carried out by unskilled people can lead to damage or malfunction. Please contact the nearest authorized technical assistance center. Always use the same type spare parts.
- Do not connect the unit to any dimmer pack.
- Do not touch any wire during operation and there may be a hazard of electric shock.
- To prevent or reduce the risk of electrical shock or fire, do not expose the fixture to rain or moisture.
- The housing must be replaced if they are visibly damaged.
- Do not look directly at the LED light beam while the fixture is on.
- There are no user serviceable parts inside the fixture. Do not open the housing or attempt any repairs by yourself. In the unlikely event your fixture may require service, please contact your nearest dealer.
- Due to the magnifying type lens, please keep the lens out of contact with direct sunlight. Direct sunlight can cause heat to build up inside of the unit, which will seriously damage unit.

2. Technical Specifications

- **Input Voltage** : 100V~240V 50/60Hz
- **Power consumption** : 40W
- **LED**: Total 8pcs
Red 2pcs, Green 2pcs, Blue 2pcs, White 2pcs
- **Dimension** : 580 x 115 x 148 mm
- **Weight** : 4.8kgs

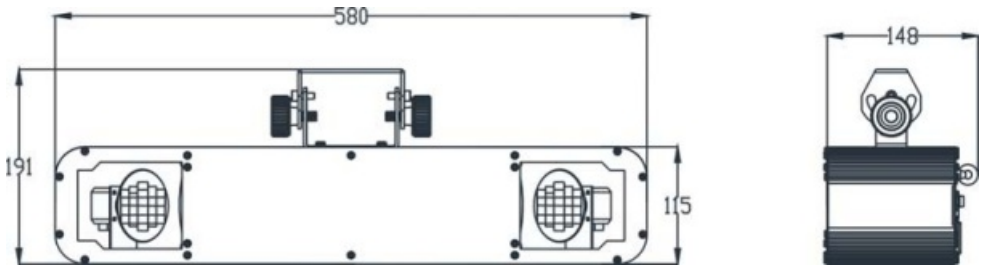

3. How to Set the Fixture

3.1 Rear panel

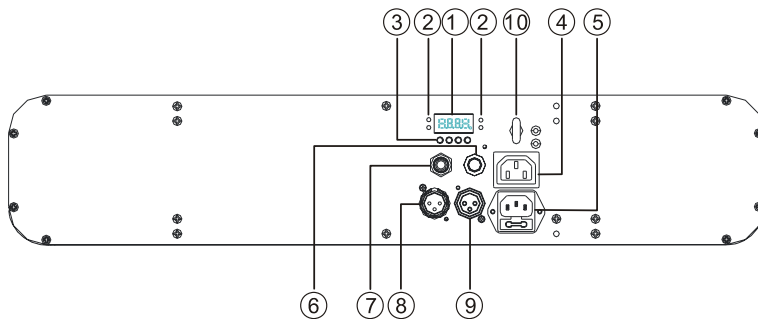

① **Display**: To show the various menus and the selected functions

② **LED**:

DMX	On	DMX input present
MASTER	On	Master Mode
SLAVE	On	Slave Mode
SOUND	Flashing	Sound activation

③ **Button:**

MENU	To select the programming functions
DOWN	To go backward in the selected functions
UP	To go forward in the selected functions
ENTER	To confirm the selected functions

- ④ **Mains output:** Connect to supply mains power to other units.
- ⑤ **Mains input:** Connect to power supply.
- ⑥ **Microphone:** Receives the sound to control the unit
- ⑦ **Only for remote control:** Connect to the 1/4" microphone jack to control the unit in Stand by and Mode functions.
- ⑧ **DMX input:** For DMX512 link, use 3/5-pin XLR plug cable to input DMX signal
- ⑨ **DMX output:** For DMX512 link, use 3-pin XLR plug cable to link the next unit..
- ⑩ **Safe Ring:** For attached the safe cable.

3.2Main Function

To select any of the given functions, press the **MENU** button to show the required option on the display. Select the function with the **ENTER** button and the display will blink. Use the **DOWN** and **UP** buttons to change the mode. Once the required mode has been selected, Press the **ENTER** button to store. To go back to the main menu without any changes press the **MENU** button. Hold and press the **MENU** button about one second or wait for one minute to exit the menu mode. The main functions are shown below:

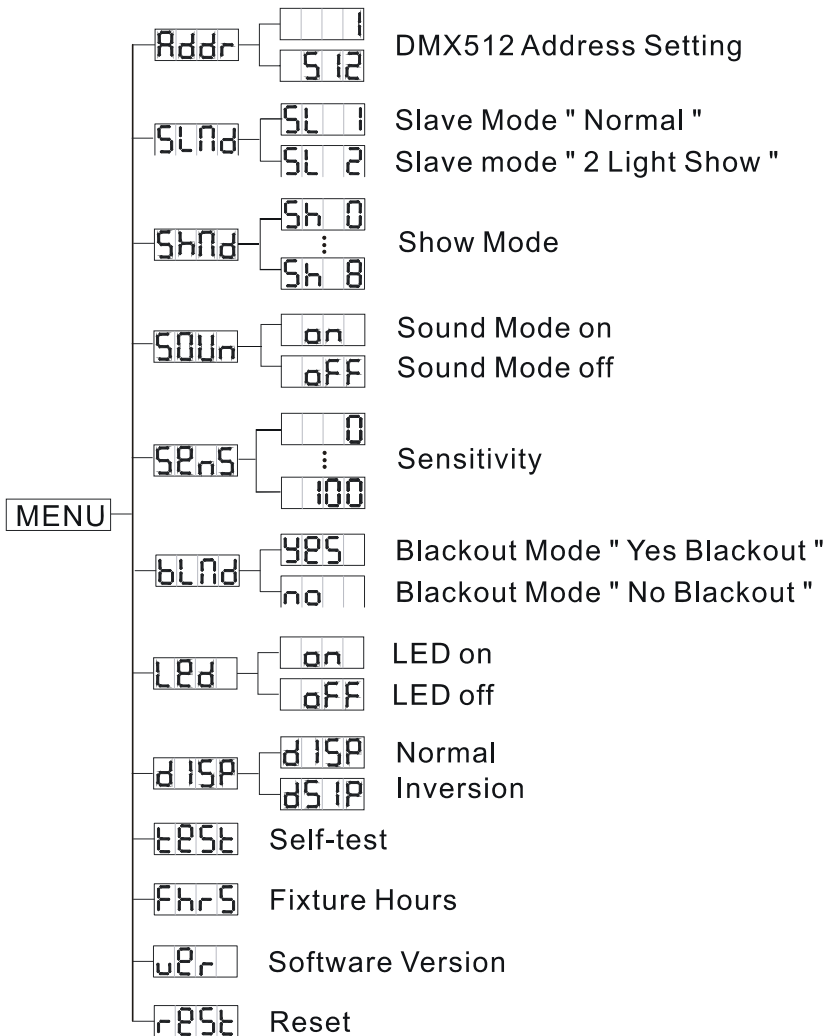

Raddr DMX 512 Address Setting

Press the **MENU** button to show **Raddr** on the display. Press the **ENTER** button and the display will blink. Use the **DOWN** and **UP** buttons to change the DMX512 address. Once the address has been selected, press the **ENTER** button to store. To return to the main menu without any changes press the **MENU** button. Hold and press the **MENU** button about one second or wait for one minute to exit the menu mode.

SLNd Slave Mode

Press the **MENU** button to show **SLNd** on the display. Press the **ENTER** button and the display will blink. Use the **DOWN** and **UP** buttons to select the **SL 1** (slave 1) or **SL 2** (Slave 2) mode. Once selected, press the **ENTER** button to store. To return to the main menu without any changes press the **MENU** button. Hold and press the **MENU** button about one second or wait for one minute to exit the menu mode.

ShNd Show Mode

Press the **MENU** button to show **ShNd** on the display. Press the **ENTER** button and the display will blink. Use the **DOWN** and **UP** buttons to select the **Sh 0** (Auto show) or **Sh 1** (show 1) or **Sh 2** (Show 2) or ... or **Sh 8** (show 8). Once selected, press the **ENTER** button to store. To return to the main menu without any changes press the **MENU** button. Hold and press the **MENU** button about one second or wait for one minute to exit the menu mode.

SOUn Sound Mode

Press the **MENU** button to show **SOUn** on the display. Press the **ENTER** button and the display will blink. Use the **DOWN** and **UP** buttons to select the **on** (sound on) or **off** (sound off). Once selected, press the **ENTER** button to store. To return to the main menu without any changes press the **MENU** button. Hold and press the **MENU** button about one second or wait for one minute to exit the menu mode.

SPnS Sound Sensitivity



Press the **MENU** button to show **SPnS** on the display. Press the **ENTER** button and the display will blink. Use the **DOWN** and **UP** buttons to change the sound sensitivity (1-100) of the unit.. Once selected, press the **ENTER** button to store. To return to the main menu without any changes press the **MENU** button. Hold and press the **MENU** button about one second or wait for one minute to exit the menu mode.

BLNd Blackout mode



Press the **MENU** button to show **BLNd** on the display. Press the **ENTER** button and the display will blink. Use the **DOWN** and **UP** buttons to select the **YES** (blackout) or **no** (normal). Once selected, press the **ENTER** button to store. To return to the main

menu without any changes press the **MENU** button. Hold and press the **MENU** button about one second or wait for one minute to exit the menu mode.

LED display

Press the **MENU** button to show  on the display. Press the **ENTER** button and the display will blink. Use the **DOWN** and **UP** buttons to select the  (display on) or  (display off) mode. Once selected, press the **ENTER** button to store. To return to the main menu without any changes press the **MENU** button. Hold and press the **MENU** button about one second or wait for one minute to exit the menu mode.

Display Inverse

Press the **MENU** button to show  on the display. Press the **ENTER** button and the display will blink. Use the **DOWN** and **UP** buttons to select the  (normal) or  (inverse), Once selected, press the **ENTER** button to store. To return to the main menu without any changes press the **MENU** button. Hold and press the **MENU** button about one second or wait for one minute to exit the menu mode.

Self-Test

Press the **MENU** button to show  on the display. Press **ENTER** button and the unit will run the built-in programmer for self-test. To return to the main menu press the **MENU** button. Hold and press the **MENU** button about one second or wait for one minute to exit the menu mode.

Fixture Hours

Press the **MENU** button to show  on the display. Press the **ENTER** button and the display will show the number of working hours of the unit. To return to the main menu press the **MENU** button. Hold and press the **MENU** button about one second or wait for one minute to exit the menu mode.

Software version

Press the **MENU** button to show  on the display. Press the **ENTER** button and the display will show the version of software inside the unit. To return to the main menu press the **MENU** button. Hold and press the **MENU** button about one second or wait for one minute to exit the menu mode.

RESET Reset

Press the **MENU** button to show **RESET** on the display. Press **ENTER** button and all channels of the unit will return to their standard position. To go back to the functions press the **MENU** button again. Hold and press the **MENU** button about one second or wait for one minute to exit the menu mode.

4. How to Control the Unit

You can operate the unit in three ways:

1. Master/slave built-in preprogram function
2. Easy controller
3. Universal DMX controller

There is no need to turn the unit off when you change the DMX address, as new DMX address setting will be affected at once. Each time you turn the unit on, it will show

"**L248**" on the display. After that the unit will be ready to receive a DMX signal or run the built in programs.

4.1 Master/Slave Built In Preprogrammed Function

By linking the units in master/slave connection, the first unit will control the other units to give an automatic, sound activated, synchronized light show. This function is good when you want an instant show. You have to set the first unit in master mode and select **SH 0** (auto show), **SH 1** (show 1) or ...or **SH 8** (show 8). Its DMX input jack will have nothing plugged into it, and its master LED will be constantly on and sound LED will flash to the music. The slave units will have to select **SL 1** (normal) or **SL 2** (2 light show) mode, Their DMX cables plugged into the DMX input jacks (daisy chain) and the slave led lights will constantly on.

2-light show

In slave mode, **SL 1** means the unit works as the master unit and **SL 2** means 2-light show. In order to create a great light show, you can set **SL 2** on the second unit to get contrast movement to each other, even if you have only two units.

4.2. Easy Controller (by CA-8)

The easy remote control is used only in master/slave mode. By connecting to the 1/4" microphone jack of the first unit, you will find that the remote controller on the first unit will control all the other units in Stand by, and Mode selection.



Blackout	Blackout the unit		
Function	1. Synchronous Strobe 2. Two Light Strobe 3. Sound Strobe	Select Show (Show 1-8)	Rotation Speed 1. Fast 2. Middle 3. Slow
Mode	Strobe (LED OFF)	Show (LED ON)	Speed (LED blinking)

4.3 DMX Controller

By using a universal DMX controller to control the units, you will need to set a DMX address from 1 to 512 so that the units can receive the DMX signal.

Press the **MENU** button to show **Raddr** on the display. Press the **ENTER** button and the display will blink. Use the **DOWN** and **UP** buttons to change the DMX512 address. Once the address has been selected, press the **ENTER** button to store. To return to the main menu without any changes press the **MENU** button or wait for one minute.

Please refer to the following diagram to address your DMX512 channels for the first 4 units:

6 channels:

				1
--	--	--	--	---











				7
--	--	--	--	---

				13
--	--	--	--	----

				19
--	--	--	--	----

5. DMX512 Configuration

6-CH mode:

DMX512 Configuration					
6 Channel Mode					
Ch1	Ch2	Ch3	Ch4	Ch5	Ch6
Dimmer/Strobe	Color	Roller	Dimmer/Strobe	Color	Roller
248-255  Open 200-247  100%  008-199  0% 000-007  No function	240-255 Color 15 224-239 Color 14 208-223 Color 13 192-207 Color 12 176-191 Color 11 160-175 Color 10 144-159 Color 9 128-143 Color 8 112-127 Color 7 096-111 Color 6 080-095 Color 5 064-079 Color 4 048-063 Color 3 032-047 Color 2 016-031 Color 1 000-015 Black out	246-255 Stopped 135-245 Rotation slow to fast 121-134 Stopped 010-120 Rotation fast to slow 000-009 Stopped	248-255  Open 200-247  100%  008-199  0% 000-007  No function	240-255 Color 15 224-239 Color 14 208-223 Color 13 192-207 Color 12 176-191 Color 11 160-175 Color 10 144-159 Color 9 128-143 Color 8 112-127 Color 7 096-111 Color 6 080-095 Color 5 064-079 Color 4 048-063 Color 3 032-047 Color 2 016-031 Color 1 000-015 Black out	246-255 Stopped 135-245 Rotation slow to fast 121-134 Stopped 010-120 Rotation fast to slow 000-009 Stopped

6. DMX512 Connections

The DMX512 is widely used in intelligent lighting control, with a maximum of 512 channels.

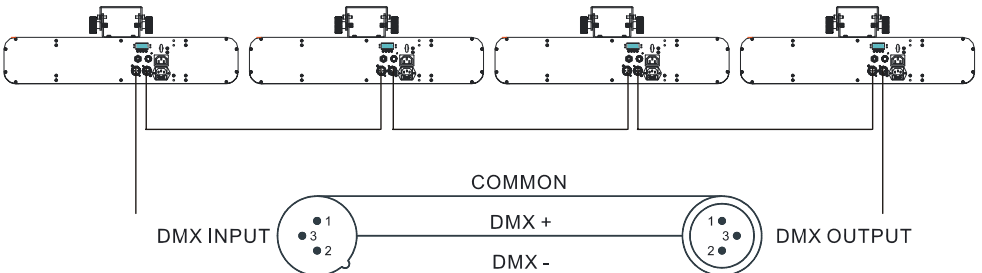

Termination reduces signal errors and voids signal transmission problems and interference. It is always advisable to connect a DMX terminal. (Resistance 120 ohm 1/4W) between pin2(DMX-) and pin3(DMX+) of the last fixture.



1. Connect the fixture together in a “daisy chain” with the XLR plug cable from the output of the fixture to the input of the next fixture. The cable cannot be branched or split to a “Y” cable. Inadequate or damaged cables, bad solder joints or corroded connectors can easily distort the signal and shut down the system

2. The DMX output and input connectors pass-through to maintain the DMX circuit when one of the units' power is disconnected.
3. At last fixture, the DMX cable has to be terminated with a terminator to reduce signal errors. Solder a 120-ohm 1/4W resistor between pin 2(DMX-) and pin 3(DMX+) into a 3-pin XLR-plug and plug it in the DMX-output of the last fixture.
4. Each lighting fixture needs to have an address set to receive the data sent by the controller. The address number is between 0-511 (usually 0 & 1 are equal to 1).
5. 3 pin XLR: Pin 1: GND, Pin 2: Negative signal (-), Pin 3: Positive signal (+)
5 pin XLR: Pin 1: GND, Pin 2: Negative signal (-), Pin 3: Positive signal (+),
Pin4/5: not used

7. Troubleshooting

Following are a few common problems that may occur during operation. Here are some suggestions for easy troubleshooting:

A. The fixture does not work, no light

1. Check the connection of power and main fuse.
2. Measure the mains voltage on the main connector.

B. Not responding to DMX controller

1. DMX LED should be on. If not, check DMX connectors, cables to see if linked properly.
2. If the DMX LED is on and no response to the channel, check the address settings and DMX polarity.
3. If you have intermittent DMX signal problems, check the cables or PCB of the fixture or the previous one.
4. Try another DMX controller.
5. Check if the DMX cables run near or run alongside to high voltage cables that may cause interference to DMX interface circuit.

C. Some fixtures don't respond to the easy controller

1. You may have a break in the DMX cabling. Check the LED for the response of the master/ slave mode signal.

2. Wrong DMX address in the fixture. Set the proper address.

D. No response to the sound

1. Make sure the fixture is not receiving a DMX signal.
2. Check microphone to see if it is good by tapping the microphone.

8. Fixture Cleaning

The cleaning of internal must be carried out periodically to optimize light output. Cleaning frequency depends on the environment in which the fixture operates: damp, smoky or particularly dirty surrounding can cause greater accumulation of dirt on the fixture's optics.

- Clean with soft cloth using normal glass cleaning fluid.
- Always dry the parts carefully.
- Clean the external optics at least every 20 days. Clean the internal optics at least every 30/60 days.

EC - Declaration of Conformity

We declare that our products (lighting equipments) comply with the following specification and bears CE mark in accordance with the provision of the Electromagnetic Compatibility (EMC) Directive 89/336/EEC.

EN55014-2: 1997 A1: 2001, EN61000-4-2: 1995; EN61000-4-3: 2002;

EN61000-4-4: 1995; EN61000-4-5: 1995, EN61000-4-6: 1996,

EN61000-4-11: 1994.

&

Harmonized Standard

EN60598-1: 2000+ALL: 2000+A12: 2002

Safety of household and similar electrical appliances

Part 1: General requirements

Innovation, Quality, Performance